

Sheet:	
File: power_input.kicad_sch	
Title:	
Size: A4	Date:
Kicad E.D.A. kicad (7.0.0)	
Rev:	
	Id: 2/3

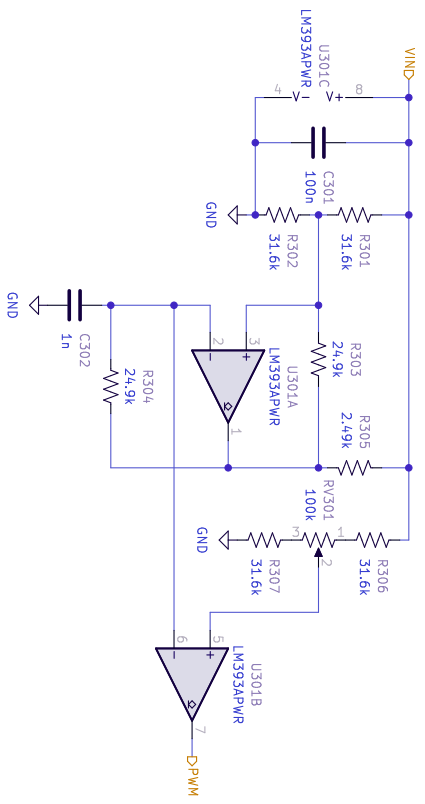

optional PWM generator / onboard dimmer
 Important: VIN_Drv must be within LM393 voltage rating!

Sheet:	
File: pwm_generator.kicad_sch	
Title:	
Size: A4	Date:
Kicad E.D.A. kicad (7.0.0)	
Rev:	
Id: 3/3	